

SURFACE KEY

MAGENTA	visible (general) surface
RED	70-120µm (main surface)
GREEN	40-120µm (secondary surface)
CYAN	0-120µm (tertiary surface)
BLUE	only powdermist allowed
ORANGE	free of coating
VIOLETT	high gloss
WITHOUT COLOUR	raw

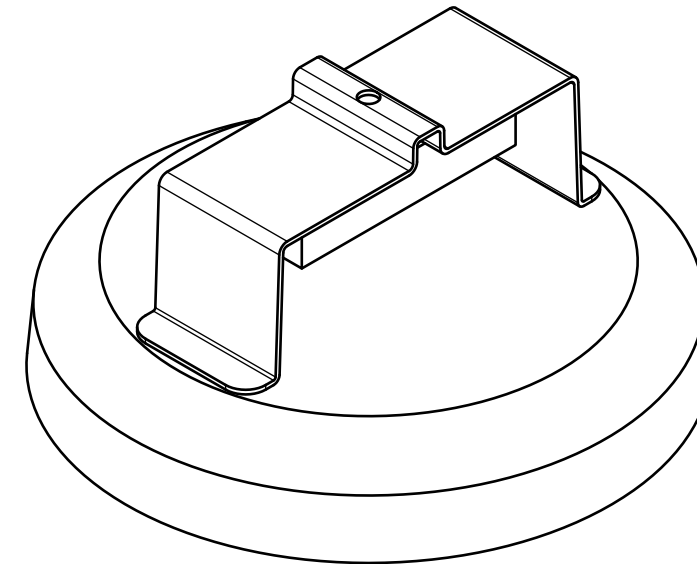
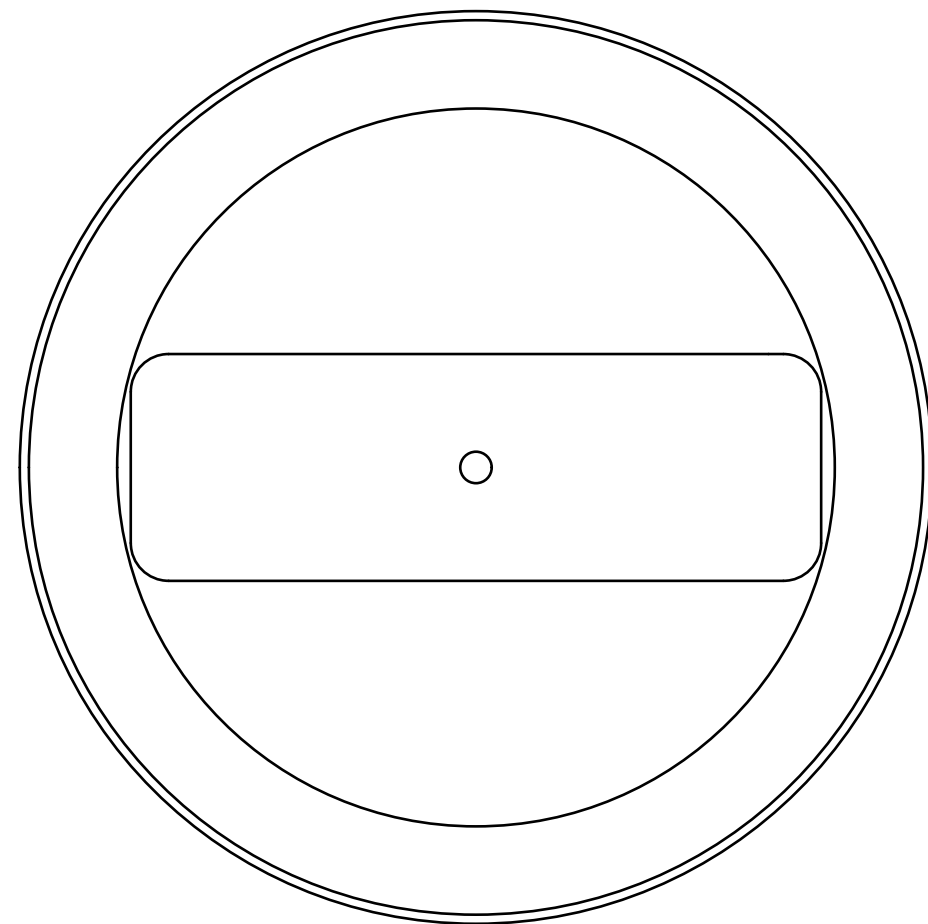
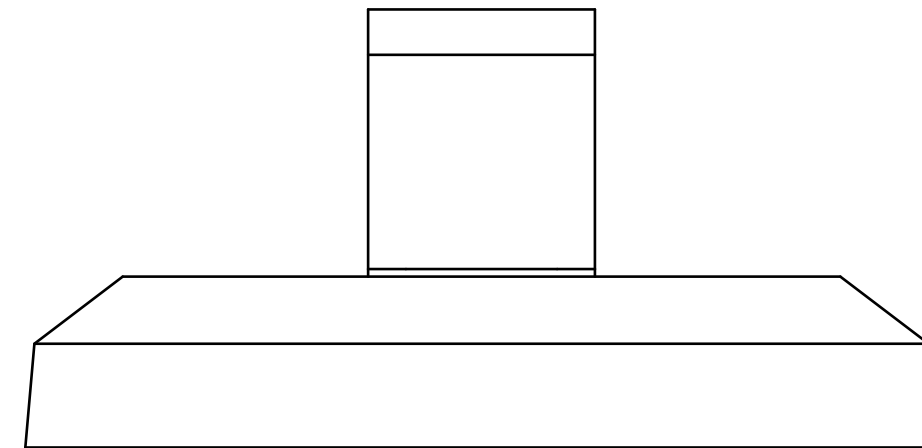
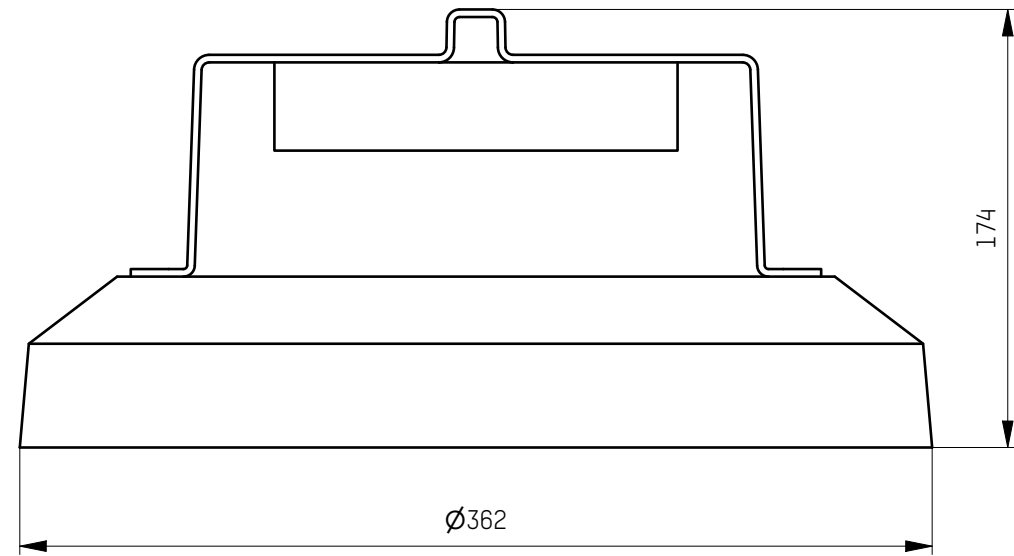

00.1	drawing updated	17.04.2023	Bresser
00	first release	05.04.2022	Palfi
rev.	description	checked date	checked by
REVISIONS-HISTORY			

technical information / manufacturing note		general manufacturing tolerances N/A	drawn by thopal	MOLTO LUCE®
		material ACC. TECHN. INFO	creation date 05.04.2022	
weight 0,000 kg	surface 377758 mm^2	description SIMPLE	drawing number ENG000025712	
surface finish N/A	surface according ISO 1302	undimensioned edges according DIN ISO 13715	article number 157-0220xxxxxxxxxx	
all dimensions and tolerances related uncoated surfaces		threads must be free of coating max. thickness of coating: 120µm	scale 1 : 3	sheet 1 of 1 A3

The unauthorized and / or against the rules use of these documents and possible attachment are not permitted and are judicially pursued