

NOA SYSTEM

208-19170232

flexible connector XTS 23-2

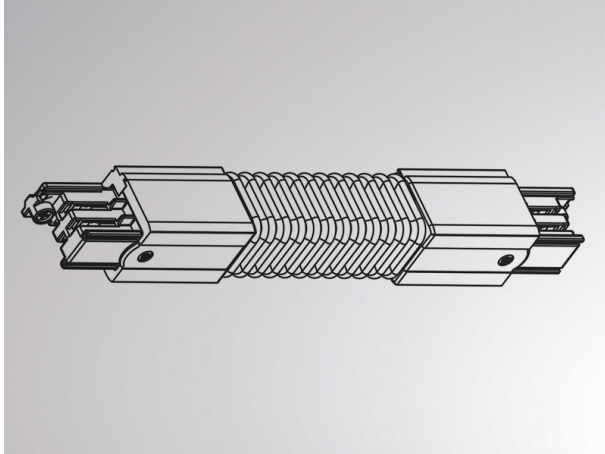

DRAWING

TECHNICAL DETAILS



Dimming	not dimmable
Voltage [V]	220-240V 50/60HZ
Material	synthetic
Length [mm]	182
Width [mm]	32
Height [mm]	33
IP protection class	IP20
Voltage class	protection cl. I
Net weight [kg]	0,13
Colour lamp	black
RAL	9005
EAN-Number	6410014506230

LIGHT DISTRIBUTION CURVE



The values are rated values. Power and luminous flux are initially subject to a tolerance of +/- 10%. Colour temperature tolerance: +/- 150 K. The values apply to an ambient temperature of 25°C unless otherwise specified.